



Measuring Guide

Thank you for choosing Shutters & Shades to supply your new DIY shutters. Here is our step-by-step guide to measuring & choosing the right shutters before placing your order. Please note that that this document is as a guide only, all windows are different.

The following document covers the most common window finishes, but should your window not fall into one of the finishes described, don't fear! Please get in touch with us at info@shuttersandshades.co.uk with a photo of your window or request a video survey to allow us to help you with the technical detail.

While we can help advise on what measurements to use, without being fully present there are elements we cannot see. So please, take your time, check and re check your measurements to ensure a simple & successful installation.

Please also note that there are some products and services that are not available when ordering via our online DIY service, please refer to the product range and styles to see what can be ordered online.

Bay windows, tracking system and shaped windows are not available to order online, if you would like to order one of these systems, please contact us to help us advise you.

If at any point during your measure you require assistance from our qualified and experienced team just call us on 0203 771 3892 or info@shuttersandshades.co.uk

While it is very important to provide accurate measurements, please be assured after your order is placed online, our team will contact you prior to production to check & run through all technical details with you.

Preparation

Preparation is key! Before you start, we recommend you have the following items to hand.

- ! Steel tape measure
- ! Spirit level
- ! Paper & Pen or download our survey form.
- ! Masking tape and template paper (brown or lining)



! Familiarise yourself with our frame guide and measuring overview.

Considerations – Panels, Louvres & Frame Types.

Before starting, make sure you have selected a shutter style - full height, café style or tier on tier. If you are unsure our website provides further details & images of the options.

Top tips from the Shutter Experts...

Measuring is simple but not every window is the same. So, follow our tips to get the perfect measure...

- ! Email us a photo of your window if there is anything you're not sure of
- ! Watch out for big handles, alarm sensors or telephone jacks.
- ! Position your frames out the way of inward opening windows
- ! Make sure you've enough space for the slats to tilt without hitting your window handles.
- ! Measure three widths and three lengths
- ! Provide the smallest dimensions for inside mount

Which Louvre width do you prefer?

Whilst louvre width is mainly down to the individual preference, remember that wider louvres will allow more light into the room when in the open position. It is vitally important that the backs of the louvres are free from obstructions, such as window handles, as this will hinder the operation of the louvres. Remember to check that the chosen louvre width is available in the selected range.

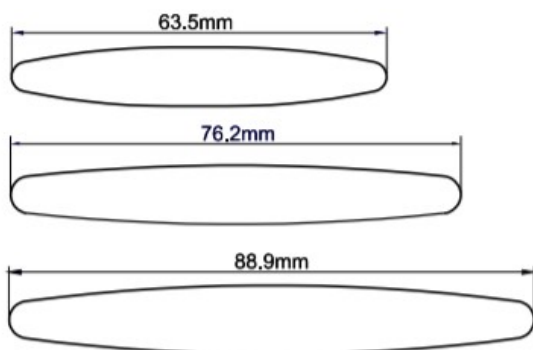

NB not to scale

Fitting Shutters Inside the Recess or on Sash Windows (Inside the Architrave)

The recess is the space created by a window sill, setting the window back from the wall, it is the depth.

The majority of installations are fitted inside the recess or onto the sash box inside the architrave. This results in the shutters being as close as possible to the glass, to maintain use of the windowsill or results in the frame not overhanging the windowsill in the case of a sash window.

If you have a deep recess, the disadvantage is that the reveal wall will prevent the panels from folding completely back, as they can only fold 90 degrees or until they touch the walls. If fitted flat on the outside of the recess (please see outside recess measure guide) or within but at the front of the recess (e.g. with a 'Z frame') the panels will have the advantage of being able to be folded back against the wall.

There are two key considerations to be made at this point.

Firstly, is an inside recess installation possible? Check the window alignment by measuring the window opening from corner to corner across both diagonals. If the dimensions vary by more than 12mm we recommend that an inside recess installation should not be attempted.

Secondly, the question of whether the panels will be folded back on a regular basis is important so as to determine the appearance of the panels in each case. The reality is that in urban environments the shutters usually remain across the window with the louvres being adjusted according to the time of day. However, when shutters are required to be folded back on a daily basis, it is important to give more consideration to how they will fold back and their subsequent appearance.

How many panels do you envisage to cover the width of the window?

The number of panels should be determined by the type and style of the window in question, taking into consideration the position of the vertical glazing bars and whether the panels are required to fold back at 90 or 180 degrees. The maximum width to which an individual panel can be manufactured varies depending on the material chosen. See full product spec for further details. Wider panels can be made, but only without warranty. Remember that when two panels meet, the combined width of the two stiles is 82mm. More panels = more stiles = less light.

Frame Styles

Typically, we offer 4 frames for shutters to be mounted to. Insert L, Deep Plain L, Bull nose Z and Camber Deco.

Insert L Frame

This is the most common frame used for face fixing installs. The Insert L frame (iL) comes in a range of depths (46mm, 60mm and 76mm). These depths house the following louvre sizes respectively; 64mm, 76mm and 89mm).

The iL frame is 38mm at the back of the frame and requires a minimum space of 40mm to mount the shutter.

INSERT L

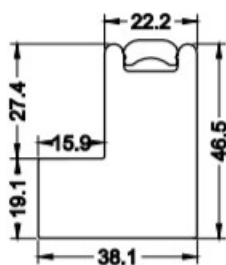

46mm

(for 64mm louvre)

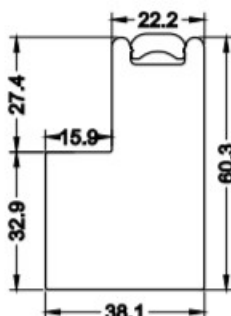

60mm

(for 76mm louvre)

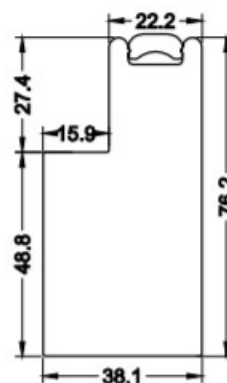

76mm

(for 89mm louvre)

Deep Plain L Frame

This frame is used when you want to side fix a shutter frame into a recess. The frame is 60mm deep and can be positioned wherever required inside a recess.

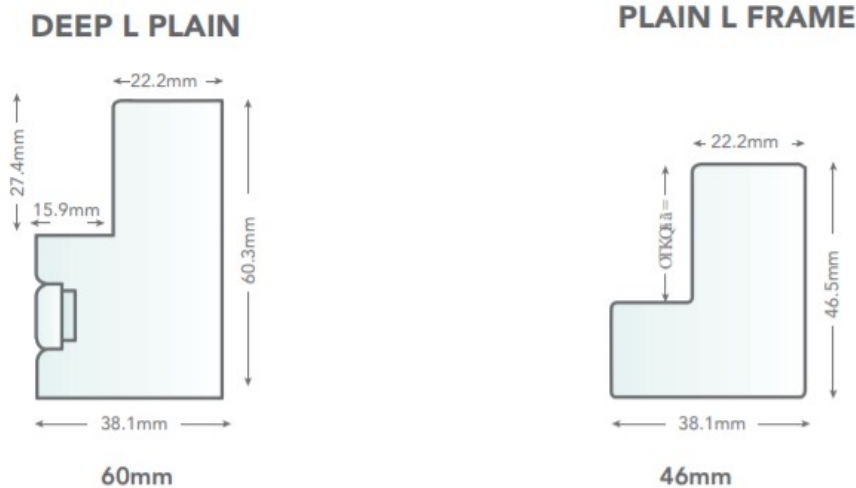

Bull Nose Z Frame

This frame is used for fitting shutters at the edge of the recess, the Z part of the frame, wraps around the edge of the recess to hide any inconsistencies in the width or height of the recess. Please note if your sill protrudes further than the wall then please ask us to remove the lip of the Z frame at the bottom so the frame is not forced forwards.

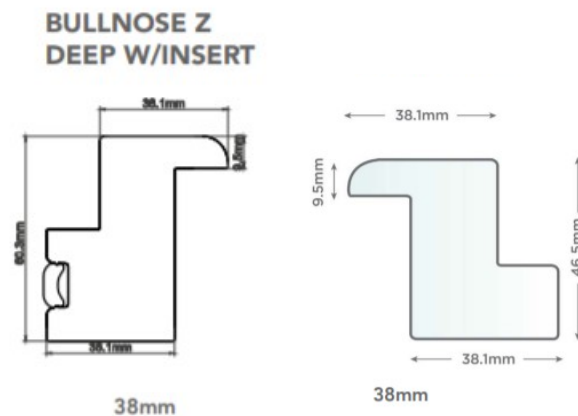

Camber Deco Frame

The Camber Deco is a decorative frame designed to fit outside the recess. When using a camber deco frame 67.5mm needs to be added to each side of the recess where you would like the frame to be positioned. Please note like the Bull Nose Z, if your sill hangs over the edge of the recess, the bottom frame needs to change to a 32mm L frame.

CAMBER DECO FRAME

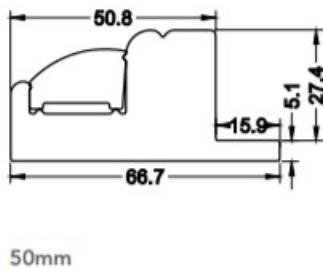

CAMBER DECO SILL PLATE

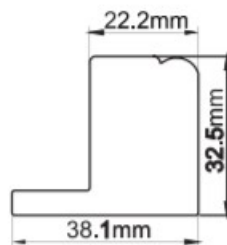

Now that you have taken all options into consideration you are ready to get measuring for your shutters!

Measuring

There are some golden rules when it comes to measuring.

- ! Always use a good quality steel tape measure for an accurate measure
- ! Measure twice –fit once
- ! As most windows are not square, be sure to check the width and drop all the way across/down the window.
- ! Always record dimensions as width x drop
- ! Ensure that louvres will not hit window furniture (handles, locks, etc) when tilted by using sufficiently deep frames or battens when face fixing. Please contact us if you require additional buildouts for the standard frames.

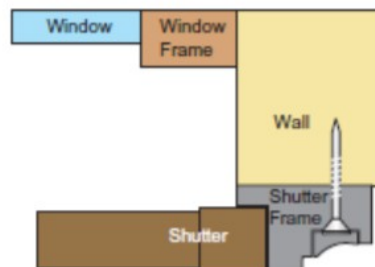
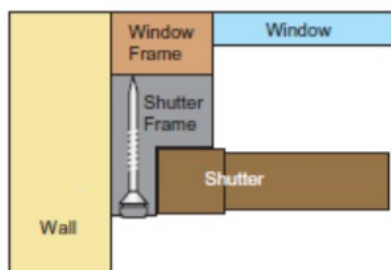

Measuring for inside recess fitting – Face Fix or side fix

First select your chosen frame. When fitting inside the recess first determine if you want to face fix or side fix and the position of the frame inside the recess.

Measure at the position you intend to fit the frame as well as the edge of the recess (if fitting close to the windowpane to ensure the shutter frame will fit).

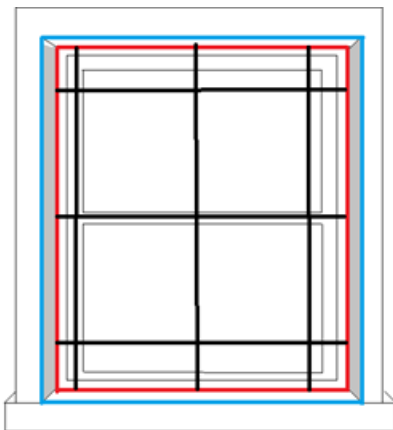

Measure the recess width at the narrowest point and deduct 5mm to determine the width

Measure the recess drop at its shallowest point and deduct 5mm to give the OD drop. Or, if the installation is 'Café style', measure from the sill to where you would like the height of the shutter to finish.

Make sure you measure in various points across the window (windows are rarely perfectly square).

If you would like to add a midrail or tier on tier position please measure this from the sill upwards.

Make a note of these measurements on a piece of paper (or download our survey template) to add to the online ordering system later.

Measuring for outside Recess Fitting – Face Fixing

Start by deciding what frame you would like to use and how many sides to your frame you would like.

For Café style we typically suggest a 3-sided frame (left, right and bottom) for Full Height or Tier on Tier a 4-sided frame.

See our frame options to familiarise yourself with the measurements for the backs of these frames. You need space to mount the frame flat.

Please note we require the overall dimensions, including the frame.

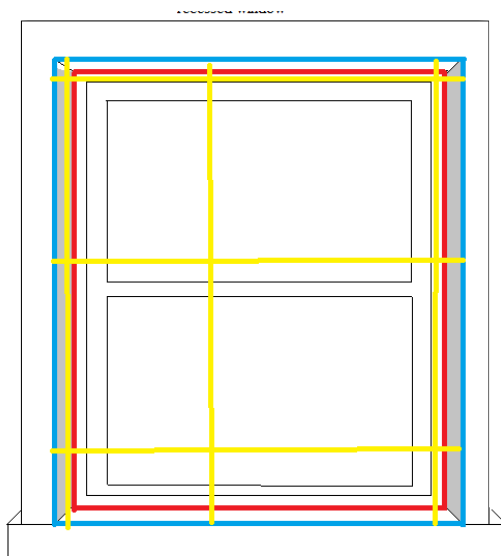

Sash window

If you have a sash window – we would recommend an insert L frame positioned between the staff bead and the architrave.

Make sure you have at least 40mm to mount the frame (if you have less than this, get in touch for further advice).

Measure the width and height in multiple locations to the widest position of the frame.

If you would like café style, tier or tier or would like to add a midrail to your shutters then please provide the measurement from the sill to the sash break in the window.

Add these measurements to a piece of paper (or download our survey template) to add to the online portal later.

Recessed window measuring outside recess

On a recessed window you could use either an insert L or a camber deco frame. Please note the frame widths differ. Please decide what frame you would like to use before measuring.

Measure the width and height of the recess in multiple locations. Add to the widest of these measurements the frame width in all directions you require a frame.

For an Insert L Frame please add 38mm. For a Camber Deco Frame please add 67.5mm. Please see our frame guide for further advice on this.

If you would like café style, tier or tier or would like to add a midrail to your shutters then please provide the measurement from the sill to the sash break in the window.

Add these measurements to a piece of paper (or download our survey template) to add to the online portal later.

Now that you have all your measurements it's time to make your order. Just follow the online process, call, or email us to make your order.